

MODEL MDL-6000 MOBILE DOCK LIFT

2 Year Parts & Labor Warranty



The MDL-6000 is a street-legal, towable dock lift that is suitable for loading/unloading trucks in the absence of any supporting infrastructure, using either hand carts, dollies or pallet jacks.

Capacity:	6,000 pounds across the entire platform when stationary
Cargo Carrying Capacity:	2,000 pounds when towed
Platform Size:	B = 54" W x 96.5" L
Lowered Height:	3 5/8"
Motor Size: Gasoline –	12HP Honda GX390
Diesel –	10HP Hatz 1B50 (-PD)
Cylinder Size:	5"
Travel Speed:	24.0 FPM or 12 seconds from truck to ground
Adjustable Lifting Height:	44.5" to 58"
Hitch Configuration:	2-5/16" Ball 3" Pintle Hook/Lunette Ring (-HPH)
Gross Weight:	5,100 pounds
Brakes:	Electric Self-Adjusting Drum Brakes with Trailer Breakaway System
Tires:	ST225/75R15 Radial
Hydraulic Fluid:	Dexron III/Mercon Multi-Purpose ATF
Lighting System:	LED stop, turn and side lights meet FMVSS 108
Electrical Connection:	7-Way Round Plug Connector – Trailer End

Mobile Dock Lift Key Features & Benefits:

- All production is done in the **USA with proven COTS components**
- All Mobile Dock Lifts conform to **ANSI MH29.1** specifications
- All models have patented **Automatic Folding Ramps (AFR's)** instead of safety chains. These eliminate the need for employees to maneuver around loads to manually lift and lower heavy ramps, thus **greatly reducing the risk of finger injuries**
- All units are made with high-grade steel. The platform, ramp, and bridge are **non-skid diamond plate**
- All Mobile Dock Lifts have a steel construction including a 3-sided lift frame which, together with the hinged ramps, provides **360-degree toe and foot protection**
- The Hydraulically Actuated Parallelogram lift mechanism ensures smooth and consistent operation with **variable speed control** for controlled ascent and descent
- Our lifts are designed to withstand severe weather conditions and reliably operate with routine maintenance which consists of regular lubrication of all bearings together with visual inspection of tires, suspension, wiring and hydraulic lines for wear and tear plus manufacturer's recommended maintenance of the on-board engine
- The closed hydraulic control system requires a routine check of the oil level and normally **does not require any oil changes**
- The Mobile Dock Lift can be provided with either an on-board **gasoline or diesel engine**
- The Mobile Dock Lift has been **certified roadworthy** by the NATM and **conforms** to all applicable US Federal Motor Vehicle Safety Standards (FMVSS) in place at time of manufacture
- Regular **preventative maintenance contracts** are available in which your lift will be serviced twice per year

Model Number	Engine	Hitch Configuration	Color
MDL-6000-B-AFR	Gasoline	2-5/16" Ball	Orange/Black
MDL-6000-B-AFR-AG	Gasoline	2-5/16" Ball	Army Forest Green CAMO – FS 595-34086
MDL-6000-B-AFR-HPH	Gasoline	3" Pintle Hook/Lunette Ring	Orange/Black
MDL-6000-B-AFR-HPH-AG	Gasoline	3" Pintle Hook/Lunette Ring	Army Forest Green CAMO – FS 595-34086
MDL-6000-B-AFR-PD	Diesel	2-5/16" Ball	Orange/Black
MDL-6000-B-AFR-PD-AG	Diesel	2-5/16" Ball	Army Forest Green CAMO – FS 595-34086
MDL-6000-B-AFR-PD-HPH	Diesel	3" Pintle Hook/Lunette Ring	Orange/Black
MDL-6000-B-AFR-PD-HPH-AG	Diesel	3" Pintle Hook/Lunette Ring	Army Forest Green CAMO – FS 595-34086

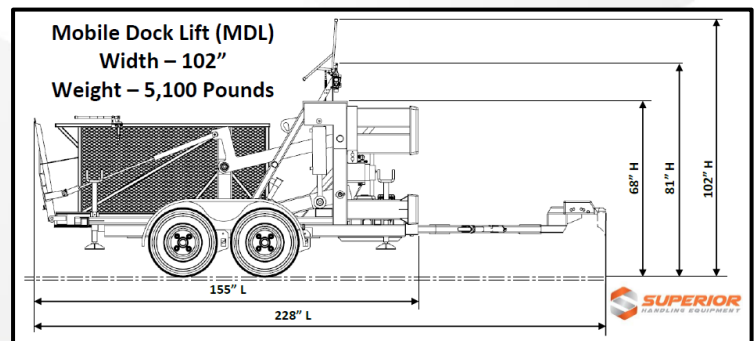

Registered to ISO 9001